

Motor cable 2 m, Plug size 17x22mm
 Motor cable 2 m, Plug size 17x22mm

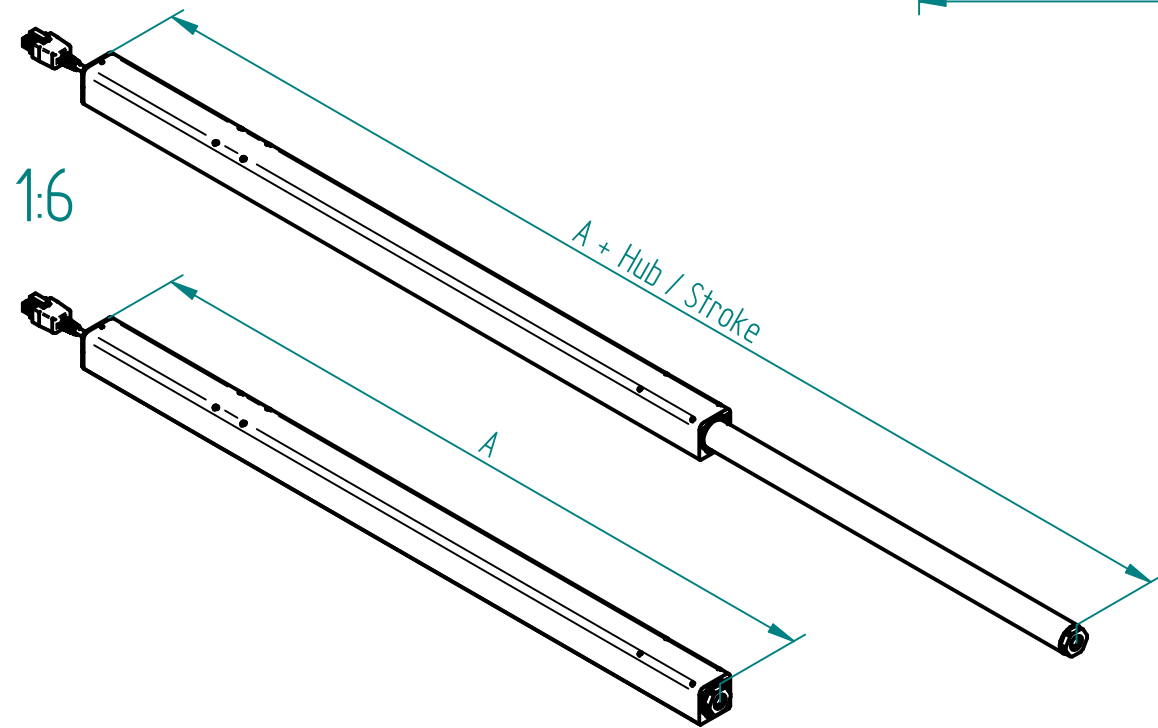
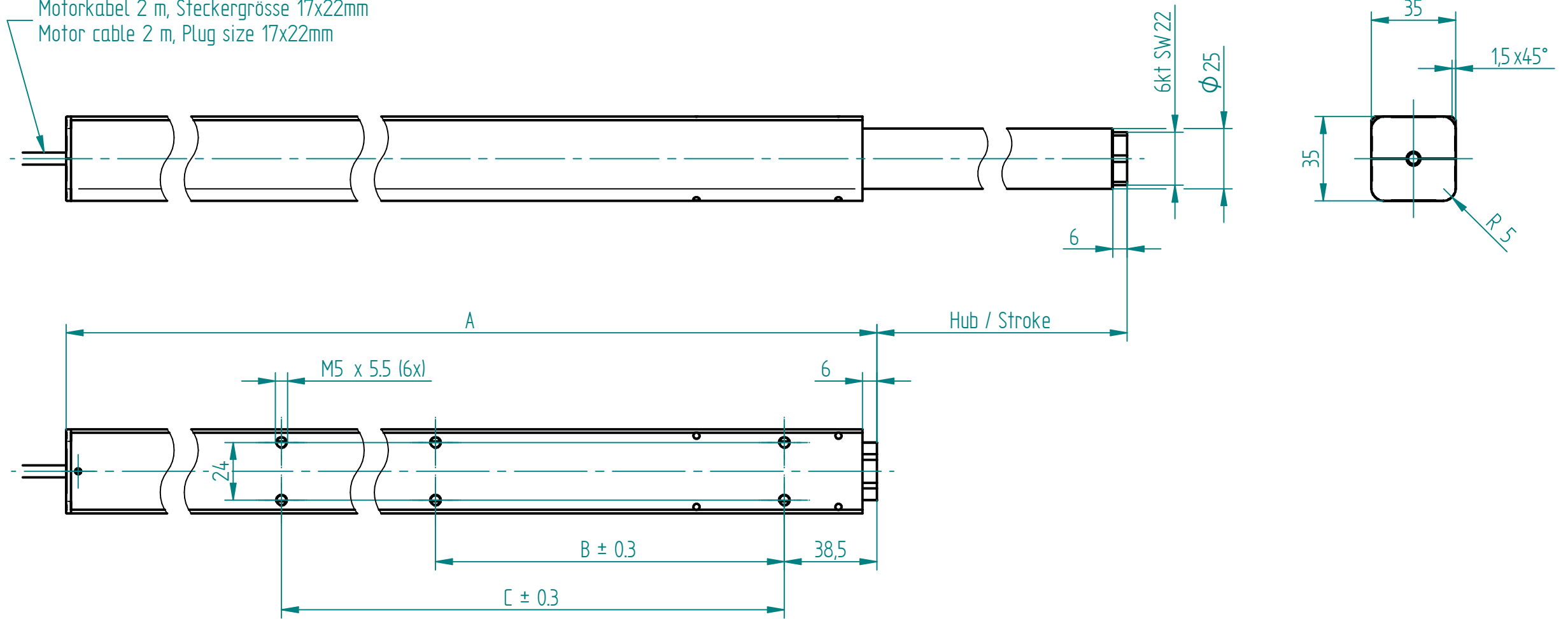

Artikelnr. / Article-No.	Name	Hub / Stroke	A	B	C
903.01002	SLA 1320	200	499	145	240
903.01003	SLA 1330	300	599	145	340
903.01004	SLA 1340	400	699	145	340

Technische Daten / technical specifications	
max. Druckbelastung / max. pressure load	1'250 N
max. Zugbelastung / max. tensile load	1'250 N
max. Systembelastung / max. system load	abhängig von Steuerung / depending on control box
Hubgeschwindigkeit / lifting speed	9 mm/s
max. stat. Biegemoment / max. static bending moment	Mb stat. 150 Nm
max. dyn. Biegemoment / max. dynamic bending moment	Mb dyn. 50 Nm
Aussenprofil / outer profile	Aluminium / aluminum
Innenprofil / inner profile	Stahl / steel
Führungart / type of guidance	Gleitführung (Kunststoff) / slide (plastics)

Index	Datum / Date	Name	Änderungsmittelung / notification of change	
	DATUM / DATE	NAME	GEWICHT / WEIGHT	BEZEICHNUNG / ASSEMBLY NAME
GEZEICHNET / DRAWN	20.01.2020	tjho	----	Lineareinheit SLA 13
GEPRÜFT / CHECKED	20.01.2020	anhe	MABSTAB / SCALE 1:2	Linear unit SLA 13
ERGO SWISS table lift systems		ZEICHNUNGSNUMMER / DRAWING NUMBER a-903.011	ARTIKELNUMMER / ASSEMBLY NUMBER 903.011	INDEX 00
			FORMAT A3	